

Kress

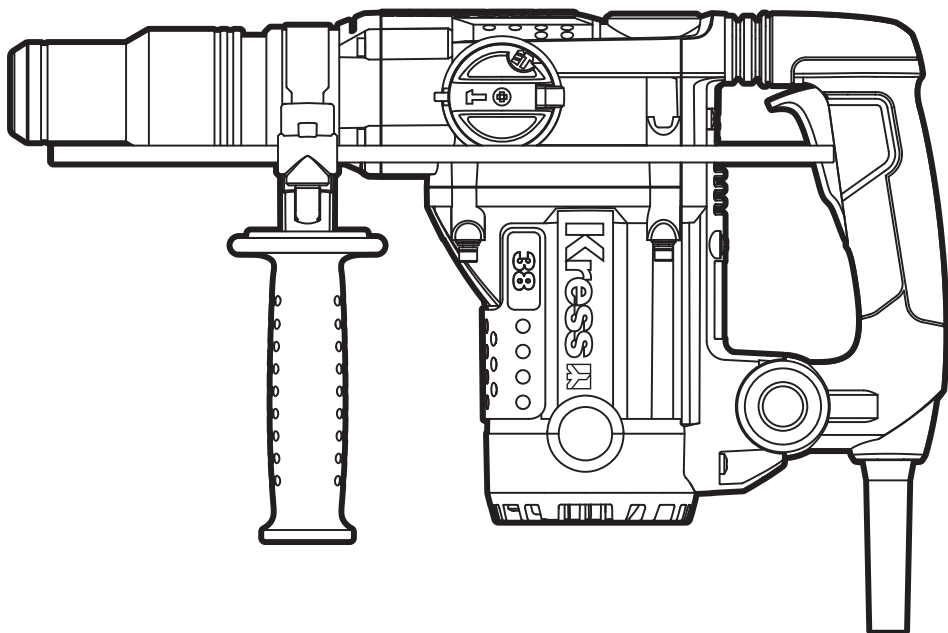

SAFETY AND OPERATING MANUAL

Rotary hammer

KUX21



GENERAL POWER TOOL SAFETY WARNINGS

 **WARNING** Read all safety warnings and all instructions. Failure to follow the warnings and instructions may result in electric shock, fire and/or serious injury.

Save all warnings and instructions for future reference.

The term "power tool" in the warnings refers to your mains-operated (corded) power tool or battery-operated (cordless) power tool.

1) WORK AREA SAFETY

- a) **Keep work area clean and well lit.** Cluttered or dark areas invite accidents.
- b) **Do not operate power tools in explosive atmospheres, such as in the presence of flammable liquids, gases or dust.** Power tools create sparks which may ignite the dust or fumes.
- c) **Keep children and bystanders away while operating a power tool.** Distractions can cause you to lose control.

2) ELECTRICAL SAFETY

- a) **Power tool plugs must match the outlet. Never modify the plug in any way. Do not use any adapter plugs with earthed (grounded) power tools.** Unmodified plugs and matching outlets will reduce risk of electric shock.
- b) **Avoid body contact with earthed or grounded surfaces, such as pipes, radiators, ranges and refrigerators.** There is an increased risk of electric shock if your body is earthed or grounded.
- c) **Do not expose power tools to rain or wet conditions.** Water entering a power tool will increase the risk of electric shock.
- d) **Do not abuse the cord. Never use the cord for carrying, pulling or unplugging the power tool. Keep cord away from heat, oil, sharp edges or moving parts.** Damaged or entangled cords increase the risk of electric shock.
- e) **When operating a power tool outdoors, use an extension cord suitable for outdoor use.** Use of a cord suitable for outdoor use reduces the risk of electric shock.
- f) **If operating a power tool in a damp location is unavoidable, use a residual current device (RCD) protected supply.** Use of an RCD reduces the risk of electric shock.

3) PERSONAL SAFETY

- a) **Stay alert, watch what you are doing and use common sense when operating a power tool. Do not use a power tool while you are tired or under the influence of drugs, alcohol or medication.** A moment of inattention while operating power tools may result in serious personal injury.

- b) **Use personal protective equipment. Always wear eye protection.** Protective equipment such as dust mask, non-skid safety shoes, hard hat, or hearing protection used for appropriate conditions will reduce personal injuries.
- c) **Prevent unintentional starting. Ensure the switch is in the off-position before connecting to power source and/or battery pack, picking up or carrying the tool.** Carrying power tools with your finger on the switch or energising power tools that have the switch on invites accidents.
- d) **Remove any adjusting key or wrench before turning the power tool on.** A wrench or a key left attached to a rotating part of the power tool may result in personal injury.
- e) **Do not overreach. Keep proper footing and balance at all times.** This enables better control of the power tool in unexpected situations.
- f) **Dress properly. Do not wear loose clothing or jewellery. Keep your hair, clothing and gloves away from moving parts.** Loose clothes, jewellery or long hair can be caught in moving parts.
- g) **If devices are provided for the connection of dust extraction and collection facilities, ensure these are connected and properly used.** Use of dust collection can reduce dust-related hazards.

4) POWER TOOL USE AND CARE

- a) **Do not force the power tool. Use the correct power tool for your application.** The correct power tool will do the job better and safer at the rate for which it was designed.
- b) **Do not use the power tool if the switch does not turn it on and off.** Any power tool that cannot be controlled with the switch is dangerous and must be repaired.
- c) **Disconnect the plug from the power source and/or the battery pack from the power tool before making any adjustments, changing accessories, or storing power tools.** Such preventive safety measures reduce the risk of starting the power tool accidentally.
- d) **Store idle power tools out of the reach of children and do not allow persons unfamiliar with the power tool or these instructions to operate the power tool.** Power tools are dangerous in the hands of untrained users.
- e) **Maintain power tools. Check for misalignment or binding of moving parts, breakage of parts and any other condition that may affect the power tool's operation. If damaged, have the power tool repaired before use.** Many accidents are caused by poorly maintained power tools.
- f) **Keep cutting tools sharp and clean.** Properly maintained cutting tools with sharp cutting edges are less likely to bind and are easier to control.

- g) **Use the power tool, accessories and tool bits etc. in accordance with these instructions, taking into account the working conditions and the work to be performed.**

Use of the power tool for operations different from those intended could result in a hazardous situation.







5) **SERVICE**









- a) **Have your power tool serviced by a qualified repair person using only identical replacement parts.** This will ensure that the safety of the power tool is maintained.

HAMMER SAFETY WARNINGS

- 1. Wear ear protectors.** Exposure to noise can cause hearing loss.
- 2. Use auxiliary handle(s), if supplied with the tool.** Loss of control can cause personal injury.
- 3. Hold power tool by insulated gripping surfaces, when performing an operation where the cutting accessory may contact hidden wiring.** Cutting accessory contacting a "live" wire may make exposed metal parts of the power tool "live" and could give the operator an electric shock.
- 4. Always wear a dust mask.**

SYMBOL

	To reduce the risk of injury, user must read instruction manual
	Wear ear protection
	Wear eye protection
	Wear dust mask
	Double insulation
	Wear protective gloves
	Before any work on the machine itself, pull the power plug from the outlet.

	Concrete
	High speed
	Low speed
	Tool Holder
	Drilling/Hammering
	Li-Ion battery. This product has been marked with a symbol relating to 'separate collection' for all battery packs and battery pack. It will then be recycled or dismantled in order to reduce the impact on the environment. Battery packs can be hazardous for the environment and for human health since they contain hazardous substances.
	Hammering
	The box is recyclable at the kerbside.
	RCM marking

ABN: Australian Business Number. By this number, business information such as entity type, status, business location etc. can be found at website <http://abr.business.gov.au>. ABN of Positec Australia Pty Limited is 14 101 682 357

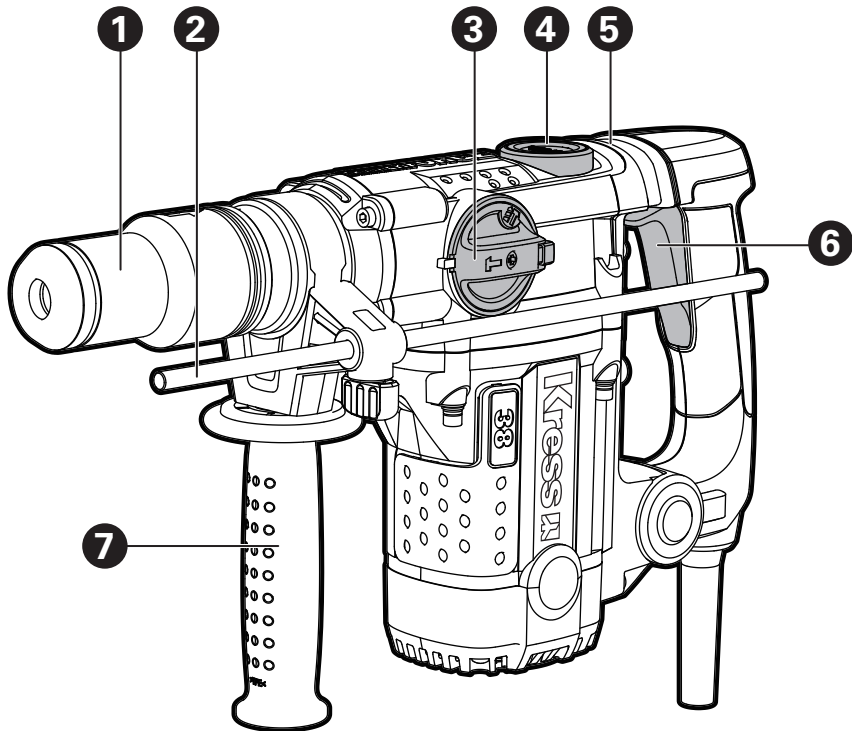

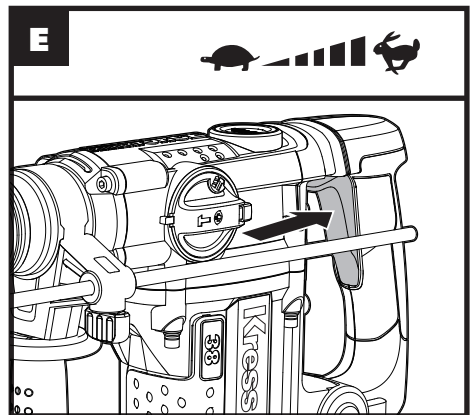
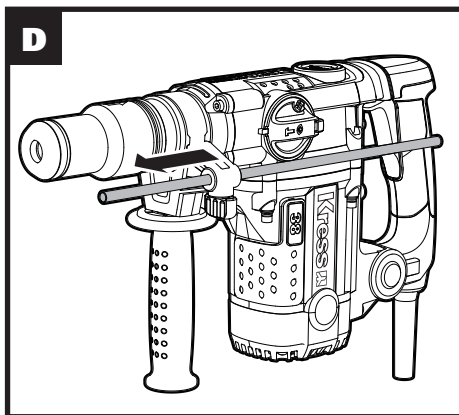
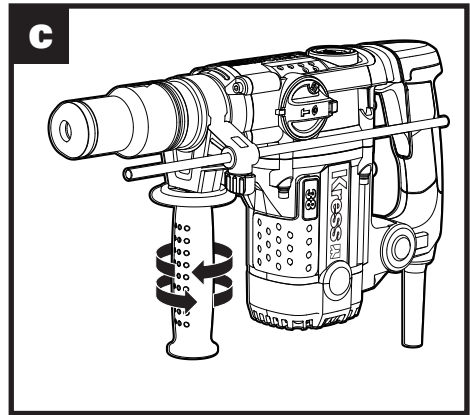
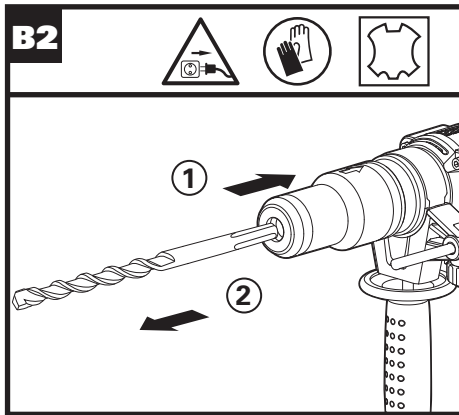
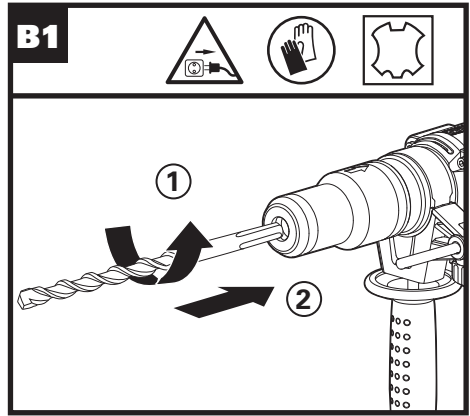
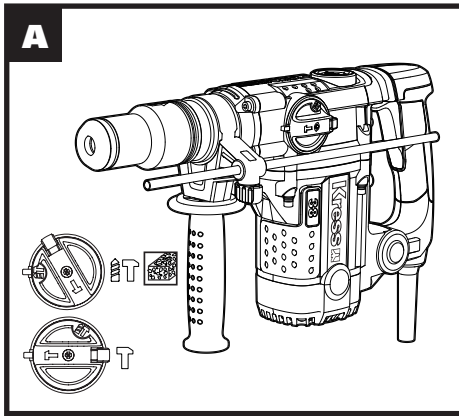

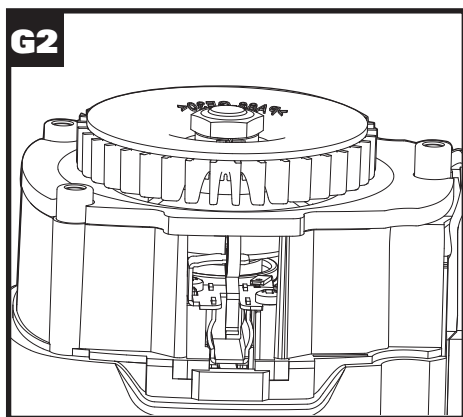
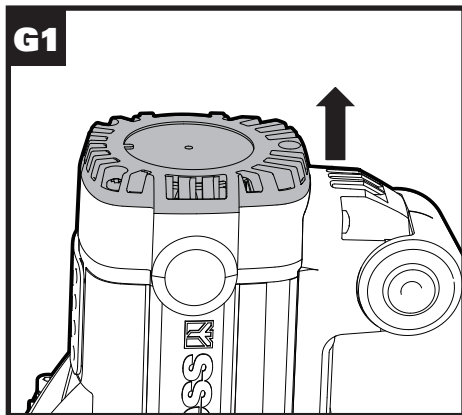
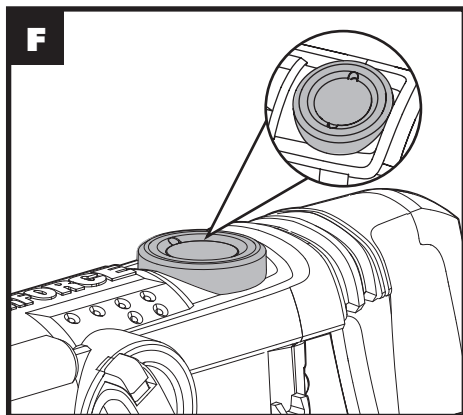

COMPONENT LIST

1. CHUCK
2. DEPTH GAUGE
3. FUNCTION MODE SELECTION SWITCH
4. GREASE BOX COVER
5. ANTI-VIBRATION HANDLE
6. ON / OFF SWITCH
7. AUXILIARY HANDLE

* Not all the accessories illustrated or described are included in standard delivery.

TECHNICAL DATA

Type **KUX21** (X21-designation of machinery, representative of Rotary Hammer drill)

Voltage	220-240V~50/60Hz
Power input	1050 W
No load speed	0-610/min
Impact rate	4150/min
Impact energy	7.5J
Protection class	 /II
Drilling capacity max. (Concrete)	38 mm
Machine weight	5.3 kg

ACCESSORIES

Auxiliary handle	1
Depth gauge	1

We recommend that you purchase your accessories from the same store that sold you the tool. Choose the type according to the work you intend to undertake. Refer to the accessory packaging for further details. Store personnel can assist you and offer advice.

OPERATING INSTRUCTIONS



NOTE: Before using the tool, read the instruction book carefully.

INTENDED USE

The machine is intended for hammer drilling in concrete, brick and stone as well as for light chiseling work.



WARNING! Before any work on the machine itself, pull the mains plug.

OPERATION

Action	Figure
Selecting The Operating Mode	See Fig. A
Inserting Drill Bits	See Fig. B1
Removing Drill Bits	See Fig. B2
Adjusting the Auxiliary Handle	See Fig. C
Using the Depth Gauge	See Fig. D
On/Off Switch	See Fig. E
Lubrication Machine	See Fig. F
Replacing the Brushes	See Fig. G1, G2
CONSTANT ELECTRONIC CONTROL	/
OVERLOAD PROTECTION	/

WORKING HINTS FOR YOUR TOOL

1. Reduce the pressure on the drill bit when it is about to break through. This will prevent the drill from jamming.
2. When drilling a large hole, first drill a pilot hole using a smaller drill bit.
3. Always apply pressure to your drill bit in a straight line, and if possible at right angles to the workpiece.
4. Never change the operating mode whilst the drill is running.
5. Do not apply excessive pressure to the tool when chiseling. Expressive force does not speed up the work.

MAINTENANCE

Remove the plug from the socket before carrying out any adjustment, servicing or maintenance.

There are no user serviceable parts in your power tool. Never use water or chemical cleaners to clean your power tool. Wipe clean with a dry cloth. Always store your power tool in a dry place. Keep the motor ventilation slots clean. Keep all working controls free of dust. Occasionally you may see sparks through the ventilation slots. This is normal and will not damage your power tool.

If the supply cord is damaged, it must be replaced by the manufacturer, its service agent or similarly qualified persons in order to avoid a hazard.

Add approximately 10 grams of 1# lubricant (about 2-3 water bottle caps) to the gearbox every 100 operating hours.

TROUBLE SHOOTING

The following table gives checks and actions that you can perform if your machine does not operate correctly. If these do not identify/solve the problem, contact Kress Customer Service.

I would add a comment here to again recommend that you apply grease to the shank of every drill bit used.

Symptom	Possible Cause	Possible Solution
Machine fails to operate	No power supply to machine	Turn power on Use another socket
	The brushes are worn out	Have a qualified person to check them, and replace them if necessary
The power and hammer efficiency of the machine is low.	Machine may be cold	Warm up the machine for 1-2 minutes until it reaches a proper working temperature
	Your drill bit does not slide freely in the chuck	Clean the dust and debris inside the chuck; Grease the shank of the bit if necessary.
	There is no enough grease oil in the gearbox	Have a qualified person to add some grease oil (about 2 or 3 bottle caps)
Your drill bit will not fit into the chuck easily	The chuck is dirty with dust and debris.	Clean the dust and debris from inside the chuck
	The shank of the bit is damaged or distorted	Change a new bit

Kress 