

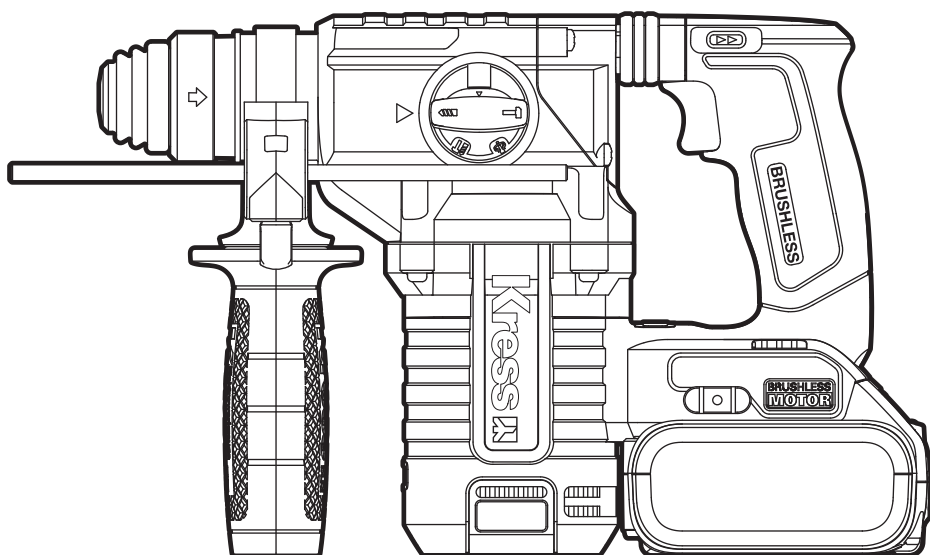

Kress



SAFETY AND OPERATING MANUAL

**Lithium-Ion Brushless Rotary Hammer
KUC61 KUC61.2 KUC61.9**

GENERAL POWER TOOL SAFETY WARNINGS

 **WARNING** Read all safety warnings and all instructions. Failure to follow the warnings and instructions may result in electric shock, fire and/or serious injury.

Save all warnings and instructions for future reference.

The term "power tool" in the warnings refers to your mains-operated (corded) power tool or battery-operated (cordless) power tool.

- 1) **Work area safety**
 - a) **Keep work area clean and well lit.** Cluttered or dark areas invite accidents.
 - b) **Do not operate power tools in explosive atmospheres, such as in the presence of flammable liquids, gases or dust.** Power tools create sparks which may ignite the dust or fumes.
 - c) **Keep children and bystanders away while operating a power tool.** Distractions can cause you to lose control.
- 2) **Electrical safety**
 - a) **Power tool plugs must match the outlet. Never modify the plug in any way. Do not use any adapter plugs with earthed (grounded) power tools.** Unmodified plugs and matching outlets will reduce risk of electric shock.
 - b) **Avoid body contact with earthed or grounded surfaces, such as pipes, radiators, ranges and refrigerators.** There is an increased risk of electric shock if your body is earthed or grounded.
 - c) **Do not expose power tools to rain or wet conditions.** Water entering a power tool will increase the risk of electric shock.
 - d) **Do not abuse the cord. Never use the cord for carrying, pulling or unplugging the power tool. Keep cord away from heat, oil, sharp edges or moving parts.** Damaged or entangled cords increase the risk of electric shock.
 - e) **When operating a power tool outdoors, use an extension cord suitable for outdoor use.** Use of a cord suitable for outdoor use reduces the risk of electric shock.
 - f) **If operating a power tool in a damp location is unavoidable, use a residual current device (RCD) protected supply.** Use of an RCD reduces the risk of electric shock.
- 3) **Personal safety**
 - a) **Stay alert, watch what you are doing and use common sense when operating a power tool. Do not use a power tool while you are tired or under the influence of drugs, alcohol or medication.** A moment of inattention while operating power tools may result in serious personal injury.
 - b) **Use personal protective equipment. Always wear eye protection.** Protective equipment such as dust mask, non-skid safety shoes, hard hat, or hearing protection used for appropriate conditions will reduce personal injuries.
 - c) **Prevent unintentional starting. Ensure the switch is in the off-position before connecting to power source and/or battery pack, picking up or carrying the tool.** Carrying power tools with your finger on the switch or energising power tools that have the switch on invites accidents.
 - d) **Remove any adjusting key or wrench before turning the power tool on.** A wrench or a key left attached to a rotating part of the power tool may result in personal injury.
 - e) **Do not overreach. Keep proper footing and balance at all times.** This enables better control of the power tool in unexpected situations.
 - f) **Dress properly. Do not wear loose clothing or jewellery. Keep your hair and clothing away from moving parts.** Loose clothes, jewellery or long hair can be caught in moving parts.
 - g) **If devices are provided for the connection of dust extraction and collection facilities, ensure these are connected and properly used.** Use of dust collection can reduce dust-related hazards.
 - 4) **Power tool use and care**
 - a) **Do not force the power tool. Use the correct power tool for your application.** The correct power tool will do the job better and safer at the rate for which it was designed.
 - b) **Do not use the power tool if the switch does not turn it on and off.** Any power tool that cannot be controlled with the switch is dangerous and must be repaired.
 - c) **Disconnect the plug from the power source and/or remove the battery pack, if detachable, from the power tool before making any adjustments, changing accessories, or storing power tools.** Such preventive safety measures reduce the risk of starting the power tool accidentally.
 - d) **Store idle power tools out of the reach of children and do not allow persons unfamiliar with the power tool or these instructions to operate the power tool.** Power tools are dangerous in the hands of untrained users.
 - e) **Maintain power tools and accessories. Check for misalignment or binding of moving parts, breakage of parts and any other condition that may affect the power tool's operation. If damaged, have the power tool repaired before use.** Many accidents are caused by poorly maintained power tools.
 - f) **Keep cutting tools sharp and clean.** Properly maintained cutting tools with sharp cutting edges are less likely to bind and are easier to control.

g) Use the power tool, accessories and tool bits etc. in accordance with these instructions, taking into account the working conditions and the work to be performed. *Use of the power tool for operations different from those intended could result in a hazardous situation.*

5) Battery tool use and care

- a) Recharge only with the charger specified by the manufacturer.** *A charger that is suitable for one type of battery pack may create a risk of fire when used with another battery pack.*
- b) Use power tools only with specifically designated battery packs.** *Use of any other battery packs may create a risk of injury and fire.*
- c) When battery pack is not in use, keep it away from other metal objects, like paper clips, coins, keys, nails, screws or other small metal objects, that can make a connection from one terminal to another.** *Shorting the battery terminals together may cause burns or a fire.*
- d) Under abusive conditions, liquid may be ejected from the battery; avoid contact. If contact accidentally occurs, flush with water. If liquid contacts eyes, additionally seek medical help.** *Liquid ejected from the battery may cause irritation or burns.*

6) Service

- a) Have your power tool serviced by a qualified repair person using only identical replacement parts.** *This will ensure that the safety of the power tool is maintained.*

HAMMER SAFETY WARNINGS

- 1. Wear ear protectors.** *Exposure to noise can cause hearing loss.*
- 2. Use auxiliary handle(s), if supplied with the tool.** *Loss of control can cause personal injury.*
- 3. Hold power tool by insulated gripping surfaces, when performing an operation where the cutting accessory may contact hidden wiring or its own cord.** *Cutting accessory contacting a "live" wire may make exposed metal parts of the power tool "live" and could give the operator an electric shock.*











SAFETY WARNINGS FOR BATTERY PACK

- a) Do not dismantle, open or shred cells or battery pack.**
- b) Do not short-circuit a battery pack. Do not store battery packs haphazardly in a box or drawer where they may short-circuit each other or be short-circuited by**

conductive materials. When battery pack is not in use, keep it away from other metal objects, like paper clips, coins, keys, nails, screws or other small metal objects, that can make a connection from one terminal to another. Shorting the battery terminals together may cause burns or a fire.

- c) Do not expose battery pack to heat or fire. Avoid storage in direct sunlight.**
- d) Do not subject battery pack to mechanical shock.**
- e) In the event of battery leaking, do not allow the liquid to come into contact with the skin or eyes. If contact has been made, wash the affected area with copious amounts of water and seek medical advice.**
- f) Keep battery pack clean and dry.**
- g) Wipe the battery pack terminals with a clean dry cloth if they become dirty.**
- h) Battery pack needs to be charged before use. Always refer to this instruction and use the correct charging procedure.**
- i) Do not maintain battery pack on charge when not in use.**
- j) After extended periods of storage, it may be necessary to charge and discharge the battery pack several times to obtain maximum performance.**
- k) Recharge only with the charger specified by Kress. Do not use any charger other than that specifically provided for use with the equipment.**
- l) Do not use any battery pack which is not designed for use with the equipment.**
- m) Keep battery pack out of the reach of children.**
- n) Retain the original product literature for future reference.**
- o) Remove the battery from the equipment when not in use.**
- p) Dispose of properly.**
- q) Do not mix cells of different manufacture, capacity, size or type within a device.**
- r) Keep the battery away from microwaves and high pressure.**

SYMBOLS

	To reduce the risk of injury, user must read instruction manual
	Warning
	Wear eye protection
	Wear ear protection
	Wear dust mask
 Li-Ion	Do not dispose of batteries. Return exhausted batteries to your local collection or recycling point
 Li-Ion	
	Do not burn
	Do not expose to rain or water
	RCM marking

ABN: Australian Business Number. By this number, business information such as entity type, status, business location etc. can be found at website <http://abr.business.gov.au>. ABN of Positec Australia Pty Limited is 14 101 682 357

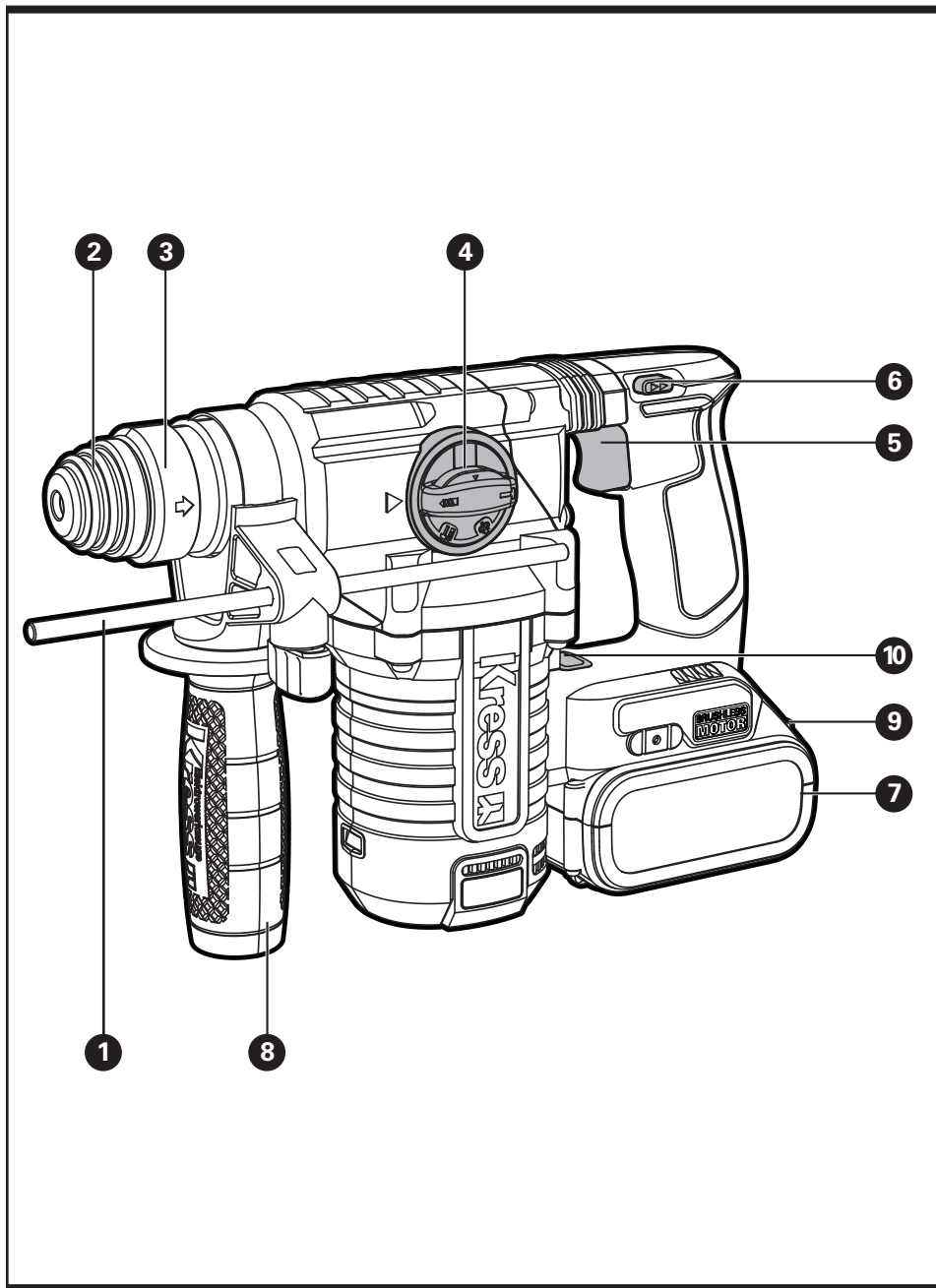

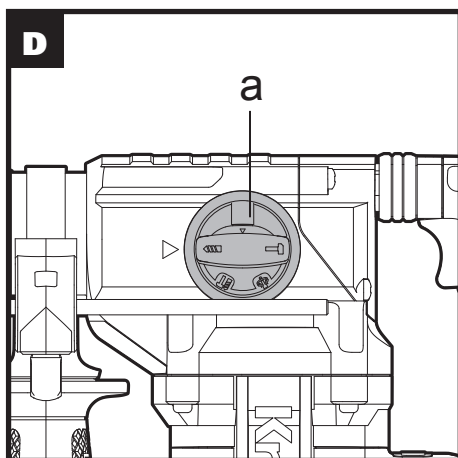
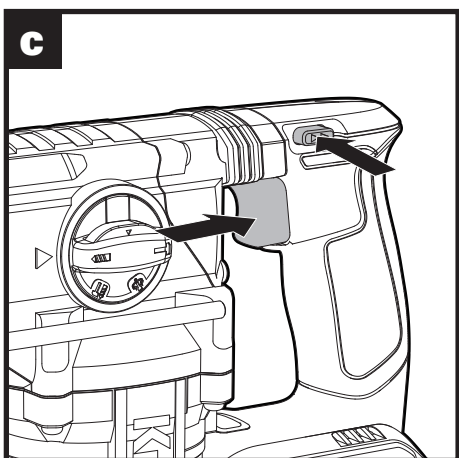
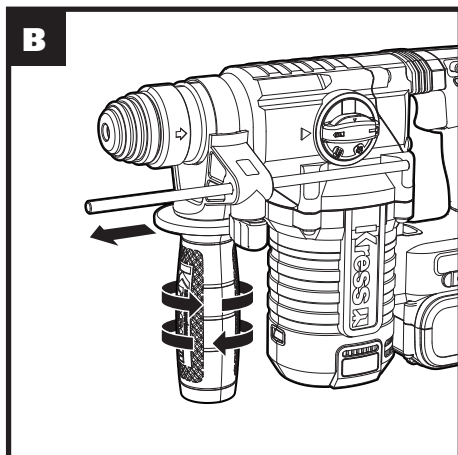
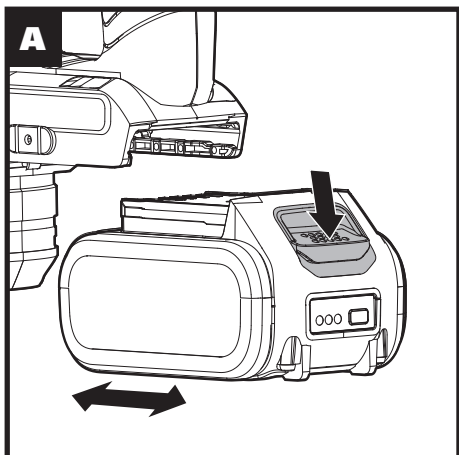

COMPONENT LIST

1. DEPTH GAUGE
2. DUST PROTECTION CAP
3. TOOL HOLDER LOCKING SLEEVE
4. FUNCTION MODE SELECTION SWITCH
5. ON/OFF SWITCH
6. FORWARD AND REVERSE ROTATION CONTROL
7. BATTERY PACK*
8. AUXILIARY HANDLE
9. BATTERY PACK RELEASE BUTTON
10. AUXILIARY FUNCTION BUTTON ON TILE

* Not all the accessories illustrated or described are included in standard delivery.

TECHNICAL DATA

Type Designation: KUC61 KUC61.2 KUC61.9
(C61 designation of machinery, representative of hammer)

	KUC61 KUC61.2	KUC61.9
Voltage	20V  Max**	
No load speed	0-1210 rpm	
Impact rate	0-5400 bpm	
Impact energy	2.2 J	
Battery model	Li-ion (KAB21)	/
Battery capacity	4.0 Ah	/
Max. drilling capacity	Steel	13 mm
	Wood	27 mm
	Masonry	24 mm
Machine weight	3.2 kg	2.6kg

** Voltage measured without workload. Initial battery voltage reaches maximum of 20 volts. Nominal voltage is 18 volts.

ACCESSORIES

	KUC61	KUC61.2	KUC61.9
4.0Ah battery pack(KAB21)	2	2	/
6A charger(KAC21)	1	1	/
Auxiliary handle	1	1	1
Depth gauge	1	1	1

We recommend that you purchase your accessories listed in the above list from the same store that sold you the tool. Refer to the accessory packaging for further details. Store personnel can assist you and offer advice.

OPERATING INSTRUCTIONS



NOTE: Before using the tool, read the instruction book carefully.

Intended Use

The machine is intended for hammer drilling in concrete, brick and stone. It is also suitable for drilling without impact in wood, metal, ceramic and plastic.

Before Putting Into Operation

A) Charging The Battery Pack

The battery pack charger supplied is matched to the Li-ion battery installed in the machine. Do not use another battery charger.

The Li-ion battery pack is protected against deep discharging. When the battery pack is empty, the machine is switched off by means of a protective circuit: The chuck no longer rotates.

In a warm environment or after heavy use, the battery pack may become too hot to permit charging. Allow time for the battery pack to cool down before recharging. When the battery pack is charged for the first time and after prolonged storage. The battery pack will accept a 100% charge after several charge and discharge cycles.

B) To Remove Or Install Battery Pack (See Fig. A)

Depress the battery pack release button to release and slide the battery pack out from your tool. After recharge, slide it back into your tool. A simple push and slight pressure will be sufficient.

OPERATION

1. INSERTING AND REMOVING DRILL BIT IN SDS

Take care that the dust protection (2) is not damaged when changing tools.

Lithium-Ion Brushless Rotary Hammer

KUC61 KUC61.2 KUC61.9

– INSERTING

Clean and lightly oil the bit before inserting. Insert the dust-free bit into the bit holder with a twisting motion until it latches.

The bit locks itself. Check the locking by pulling on the tool.

– REMOVING

Retract back the bit holder locking sleeve (3) and pull out the bit.



WARNING Your new Kress Rotary Hammer

Drill generates powerful forces to get your job done quickly and effectively. These forces may cause inferior quality SDS bits to break and jam in the chuck. We therefore recommend that only high quality SDS bits be used with this tool.

2. AUXILIARY HANDLE (SEE FIG. B)

Slide the handle onto the hammer and rotate to the desired working position. To clamp the auxiliary handle rotate the handle clockwise. To loosen the auxiliary handle, rotate the handle counter-clockwise.



WARNING: Always use the auxiliary handle.

3. ADJUSTABLE DEPTH GAUGE (SEE FIG. B)

Loosen the depth gauge by rotating the handle counter-clockwise. Slide the depth gauge until the distance between the depth gauge end and the drill bit end is equal to the depth of hole/screw you wish to make. Then clamp the depth gauge by rotating the handle clockwise.

4. ON/OFF SWITCH (SEE FIG. C)

Depress the On/Off switch (5) to start and release it to stop your tool.

– ON/OFF SWITCH WITH VARIABLE SPEED CONTROL

Depress the On/Off switch to start and release it to stop your tool. This tool has a variable speed switch (5) that delivers higher speeds with increased trigger pressure or delivers lower speeds with reduced trigger pressure - speed is controlled by varying the pressure applied to the switch.

5. SWITCH LOCK (SEE FIG. C)

The switch trigger can be locked in the OFF position. This helps to reduce the possibility of accidental starting when not in use. To lock the switch trigger, place the direction of rotation control in the center position.

6. FORWARD AND REVERSE ROTATION CONTROL (SEE FIG. C)

Forward rotation: Push the forward and reverse rotation control to the left “<<”, for drilling
Reverse rotation: Push the forward and reverse rotation control to the right “>>”, for removing the drill bits.



WARNING: Never change the direction of rotation while the tool is rotating, wait until it has stopped.

7. AUXILIARY FUNCTION ON TILE

1) Press ON/OFF switch to see the light is on or off. Light on indicates the auxiliary function is on, and light off indicate the auxiliary function is turn off.

2) When operating on the tile, press the auxiliary function button on tile (10) first, the green light on means that auxiliary function is on, then half-press switch, begin pulse auxiliary operation. Until the glaze of tile is broken, press the ON/OFF switch to the bottom and begin the drilling .

3) When operating on things rather than tile, keep the auxiliary function button closed, to insure the high efficiency when drilling.

Note:

a) Auxiliary function on tile avoids the unexpected split of tile. This auxiliary function takes the place of previous pre-drilling by glass drill on tile.

b) The auxiliary function on tile is only suitable to be used under the hammer drilling position. When operating under drilling/chiseling/ Adjust the chuck angle mode, make sure to turn the auxiliary function off .

8. FUNCTION MODE SELECTION (SEE FIG. D)

The operation of the gearbox for each application is set with the function selector dial (4). To change between functions, depress the unlocking button (a) and rotate the selector to the desired operating mode.

	Mode for simultaneous drilling and impacting of concrete, Masonry
	Mode for or drilling into steel, wood and plastics
	Mode for or chiseling
	Mode for adjust the chuck angle of chiseling NOTE: Select this function mode first, adjust the chuck angle to desired direction. Then select the function mode to “T”, operate the chiseling work.



WARNING: The operating mode selector switch may be actuated only at a standstill.

9. OVERLOAD PROTECTION

When overloaded, the motor comes to a stop. Relieve the load on the machine immediately and allow cooling for approx. 30 seconds at the highest no-load speed.

10. TEMPERATURE DEPENDENT OVERLOAD PROTECTION

When using as intended for, the power tool cannot be subject to overload. When the load is too high or the allowable battery temperature of 75 °C is exceeded, the electronic control switches off the power tool until the temperature is in the optimum temperature range again.

11. PROTECTION AGAINST DEEP DISCHARGING

The Li-ion battery is protected against deep discharging by the "Discharging Protection System". When the battery is empty, the machine is switched off by means of a protective circuit: The inserted tool no longer rotates.

WORKING HINTS FOR YOUR TOOL

If your power tool becomes over heated, set the speed to maximum and run no load for 2-3 minutes to cool the motor. SDS-plus tungsten carbide drill bits should always be used for concrete and masonry. When drilling in metal, only use HSS drill bits in good condition. Where possible use a pilot hole before drilling a large diameter hole.

PROBLEM SOLUTION

1. REASONS FOR DIFFERENT CHARGING TIMES

Your charge time can be affected by many reasons which are not defects in your product. If the battery pack is only partly discharged it may be re-charged in less than 1 hour. If the battery pack and ambient temperature are very cold then re-charging may take 1-1.5 hours. If the battery pack is very hot it will not re-charge because the internal temperature safety cutout will prevent it. If the battery pack is very hot you must remove your battery pack from the charger and allow your battery pack to cool first to ambient temperature and then recharging can be started. If you charge a second battery pack immediately after the first then the charger can be overheated. Always allow at least 15 minutes rest between battery pack charging.

2. REASONS FOR DIFFERENT BATTERY PACK WORKING TIMES

Charging time problems, having not used a battery pack for a prolonged time will reduce the battery pack working time. This can be corrected after several charge and discharge operations by charging & working with your drill. Heavy working conditions such as large screws into hard wood will use up the battery pack energy faster than lighter working conditions. Do not re-charge your battery pack below 0°C and above 30°C as this will affect performance.

MAINTENANCE

REMOVE THE BATTERY PACK FROM THE TOOL BEFORE CARRYING OUT ANY ADJUSTMENT, SERVICING OR MAINTENANCE.

Your power tool requires no additional lubrication or maintenance. There are no user serviceable parts in your power tool. Never use water or chemical cleaners to clean your power tool. Wipe clean with a dry cloth. Always store your power tool in a dry place. Keep the motor ventilation slots clean. Keep all working controls free of dust. Occasionally you may see sparks through the ventilation slots. This is normal and will not damage your power tool.

Kress 