

Kress

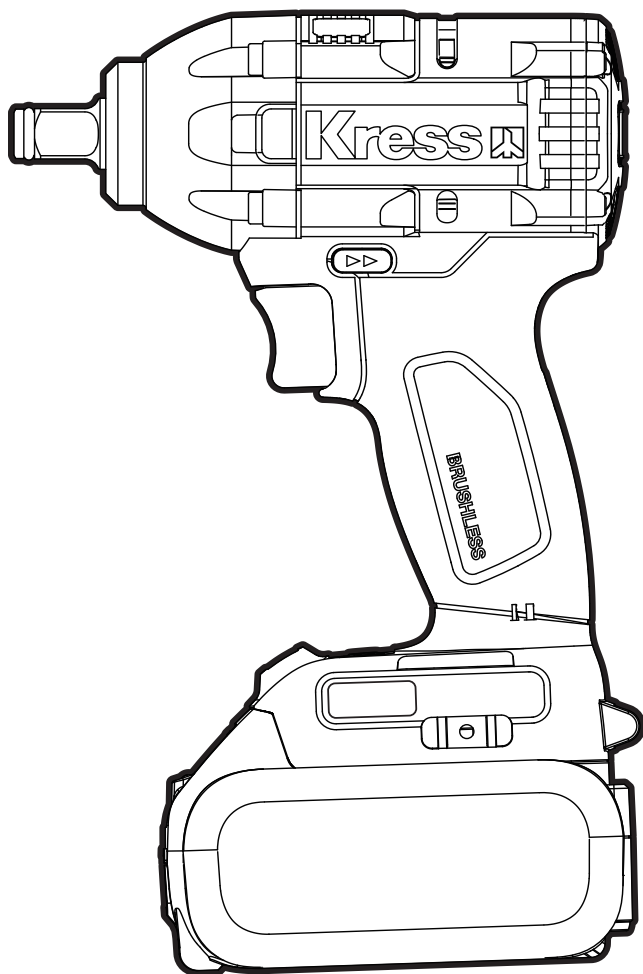

SAFETY AND OPERATING MANUAL

**Lithium-Ion Brushless Impact Wrench
KUB30 KUB30.2 KUB30.9**

MAINTENANCE

Remove the battery pack from the machine before carrying out any adjustment, servicing or maintenance.

Your power tool requires no additional lubrication or maintenance. Never use water or chemical cleaners to clean your power tool. Wipe it with a dry cloth. Wipe clean with a dry cloth. Always store your power tool in a dry place. Keep the motor ventilation slots clean. Keep all working controls free of dust.

FOR BATTERY TOOLS

The ambient temperature range for the use and storage of tool and battery is 0°C-45°C.

The recommended ambient temperature range for the charging system during charging is 0°C-40°C.

Positec Australia Pty Limited
10 Corporate Blvd Bayswater, VIC 3153, Australia

PRODUCT SAFETY

GENERAL POWER TOOL

SAFETY WARNINGS

 **WARNING** Read all safety warnings, instructions, illustrations and specifications provided with this power tool. Failure to follow all instructions listed below may result in electric shock, fire and/or serious injury.

Save all warnings and instructions for future reference.

The term "power tool" in the warnings refers to your mains-operated (corded) power tool or battery-operated (cordless) power tool.

1) Work area safety

- a) **Keep work area clean and well lit.** Cluttered or dark areas invite accidents.
- b) **Do not operate power tools in explosive atmospheres, such as in the presence of flammable liquids, gases or dust.** Power tools create sparks which may ignite the dust or fumes.
- c) **Keep children and bystanders away while operating a power tool.** Distractions can cause you to lose control.

2) Electrical safety

- a) **Power tool plugs must match the outlet. Never modify the plug in any way. Do not use any adapter plugs with earthed (grounded) power tools.** Unmodified plugs and matching outlets will reduce risk of electric shock.
- b) **Avoid body contact with earthed or grounded surfaces, such as pipes, radiators, ranges and refrigerators.** There is an increased risk of electric shock if your body is earthed or grounded.
- c) **Do not expose power tools to rain or wet conditions.** Water entering a power tool will increase the risk of electric shock.
- d) **Do not abuse the cord. Never use the cord for carrying, pulling or unplugging the power tool. Keep cord away from heat, oil, sharp edges or moving parts.** Damaged or entangled cords increase the risk of electric shock.
- e) **When operating a power tool outdoors, use an extension cord suitable for outdoor use.** Use of a cord suitable for outdoor use reduces the risk of electric shock.
- f) **If operating a power tool in a damp location is unavoidable, use a residual current device (RCD) protected supply.** Use of an RCD reduces the risk of electric shock.

3) Personal safety

- a) **Stay alert, watch what you are doing and use common sense when operating a power tool. Do not use a power tool while**

you are tired or under the influence of drugs, alcohol or medication. A moment of inattention while operating power tools may result in serious personal injury.

- b) **Use personal protective equipment. Always wear eye protection.** Protective equipment such as dust mask, non-skid safety shoes, hard hat, or hearing protection used for appropriate conditions will reduce personal injuries.
- c) **Prevent unintentional starting. Ensure the switch is in the off-position before connecting to power source and/or battery pack, picking up or carrying the tool.** Carrying power tools with your finger on the switch or energising power tools that have the switch on invites accidents.
- d) **Remove any adjusting key or wrench before turning the power tool on.** A wrench or a key left attached to a rotating part of the power tool may result in personal injury.
- e) **Do not overreach. Keep proper footing and balance at all times.** This enables better control of the power tool in unexpected situations.
- f) **Dress properly. Do not wear loose clothing or jewellery. Keep your hair, clothing and gloves away from moving parts.** Loose clothes, jewellery or long hair can be caught in moving parts.
- g) **If devices are provided for the connection of dust extraction and collection facilities, ensure these are connected and properly used.** Use of dust collection can reduce dust-related hazards.
- h) **Do not let familiarity gained from frequent use of tools allow you to become complacent and ignore tool safety principles.** A careless action can cause severe injury within a fraction of a second.
- 4) **Power tool use and care**
 - a) **Do not force the power tool. Use the correct power tool for your application.** The correct power tool will do the job better and safer at the rate for which it was designed.
 - b) **Do not use the power tool if the switch does not turn it on and off.** Any power tool that cannot be controlled with the switch is dangerous and must be repaired.
 - c) **Disconnect the plug from the power source and/or the battery pack from the power tool before making any adjustments, changing accessories, or storing power tools.** Such preventive safety measures reduce the risk of starting the power tool accidentally.
 - d) **Store idle power tools out of the reach of children and do not allow persons unfamiliar with the power tool or these instructions to operate the power tool.** Power tools are dangerous in the hands of untrained users.

- e) **Maintain power tools. Check for misalignment or binding of moving parts, breakage of parts and any other condition that may affect the power tool's operation. If damaged, have the power tool repaired before use.** *Many accidents are caused by poorly maintained power tools.*
- f) **Keep cutting tools sharp and clean.** *Properly maintained cutting tools with sharp cutting edges are less likely to bind and are easier to control.*
- g) **Use the power tool, accessories and tool bits etc. in accordance with these instructions, taking into account the working conditions and the work to be performed.** *Use of the power tool for operations different from those intended could result in a hazardous situation.*
- h) **Keep handles and grasping surfaces dry, clean and free from oil and grease.** *Slippery handles and grasping surfaces do not allow for safe handling and control of the tool in unexpected situations.*
- 5) **Battery tool use and care**
- a) **Recharge only with the charger specified by the manufacturer.** *A charger that is suitable for one type of battery pack may create a risk of fire when used with another battery pack.*
- b) **Use power tools only with specifically designated battery packs.** *Use of any other battery packs may create a risk of injury and fire.*
- c) **When battery pack is not in use, keep it away from other metal objects, like paper clips, coins, keys, nails, screws or other small metal objects, that can make a connection from one terminal to another.** *Shorting the battery terminals together may cause burns or a fire.*
- d) **Under abusive conditions, liquid may be ejected from the battery; avoid contact. If contact accidentally occurs, flush with water. If liquid contacts eyes, additionally seek medical help.** *Liquid ejected from the battery may cause irritation or burns.*
- e) **Do not use a battery pack or tool that is damaged or modified.** *Damaged or modified batteries may exhibit unpredictable behaviour resulting in fire, explosion or risk of injury.*
- f) **Do not expose a battery pack or tool to fire or excessive temperature.** *Exposure to fire or temperature above 130 °C may cause explosion.*
- g) **Follow all charging instructions and do not charge the battery pack or tool outside the temperature range specified in the instructions.** *Charging improperly or at temperatures outside the specified range may damage the battery and increase the risk of fire.*
- 6) **Service**
- a) **Have your power tool serviced by a qualified repair person using only identical replacement parts.** *This will ensure that the*

safety of the power tool is maintained.

- b) **Never service damaged battery packs.** *Service of battery packs should only be performed by the manufacturer or authorized service providers.*

IMPACT WRENCH SAFETY WARNING











1. **Hold the power tool by insulated gripping surfaces, when performing an operation where the fastener may contact hidden wiring.** *Fasteners contacting a "live" wire may make exposed metal parts of the power tool "live" and could give the operator an electric shock.*





SAFETY WARNINGS FOR BATTERY PACK

- a) **Do not dismantle, open or shred cells or battery pack.**
- b) **Do not short-circuit a battery pack. Do not store battery packs haphazardly in a box or drawer where they may short-circuit each other or be short-circuited by conductive materials.** *When battery pack is not in use, keep it away from other metal objects, like paper clips, coins, keys, nails, screws or other small metal objects, that can make a connection from one terminal to another. Shorting the battery terminals together may cause burns or a fire.*
- c) **Do not expose battery pack to heat or fire. Avoid storage in direct sunlight.**
- d) **Do not subject battery pack to mechanical shock.**
- e) **In the event of battery leaking, do not allow the liquid to come into contact with the skin or eyes. If contact has been made, wash the affected area with copious amounts of water and seek medical advice.**
- f) **Keep battery pack clean and dry.**
- g) **Wipe the battery pack terminals with a clean dry cloth if they become dirty.**
- h) **Battery pack needs to be charged before use. Always refer to this instruction and use the correct charging procedure.**
- i) **Do not maintain battery pack on charge when not in use.**
- j) **After extended periods of storage, it may be necessary to charge and discharge the battery pack several times to obtain maximum performance.**
- k) **Recharge only with the charger specified by Kress. Do not use any charger other than that specifically provided for use with the equipment.**
- l) **Do not use any battery pack which is not designed for use with the equipment.**

- m) **Keep battery pack out of the reach of children.**
- n) **Retain the original product literature for future reference.**
- o) **Remove the battery from the equipment when not in use.**
- p) **Dispose of properly.**
- q) **Do not mix cells of different manufacture, capacity, size or type within a device.**
- r) **Keep the battery away from microwaves and high pressure.**

SYMBOL

	To reduce the risk of injury, user must read instruction manual
	Warning
	Wear ear protection
	Wear eye protection
	Wear dust mask
 Li-Ion	Li-Ion battery. This product has been marked with a symbol relating to 'separate collection' for all battery packs and battery pack. It will then be recycled or dismantled in order to reduce the impact on the environment.
 Li-Ion	Battery packs can be hazardous for the environment and for human health since they contain hazardous substances.
	Batteries may enter water cycle if disposed improperly, which can be hazardous for ecosystem. Do not dispose of waste batteries as unsorted municipal waste.
	Do not burn
	Wear protective gloves
	High speed

	Low speed
	Lock
	The box is recyclable at the kerbside.
	RCM marking

ABN: Australian Business Number. By this number, business information such as entity type, status, business location etc. can be found at website <http://abr.business.gov.au>. ABN of Positec Australia Pty Limited is 14 101 682 357

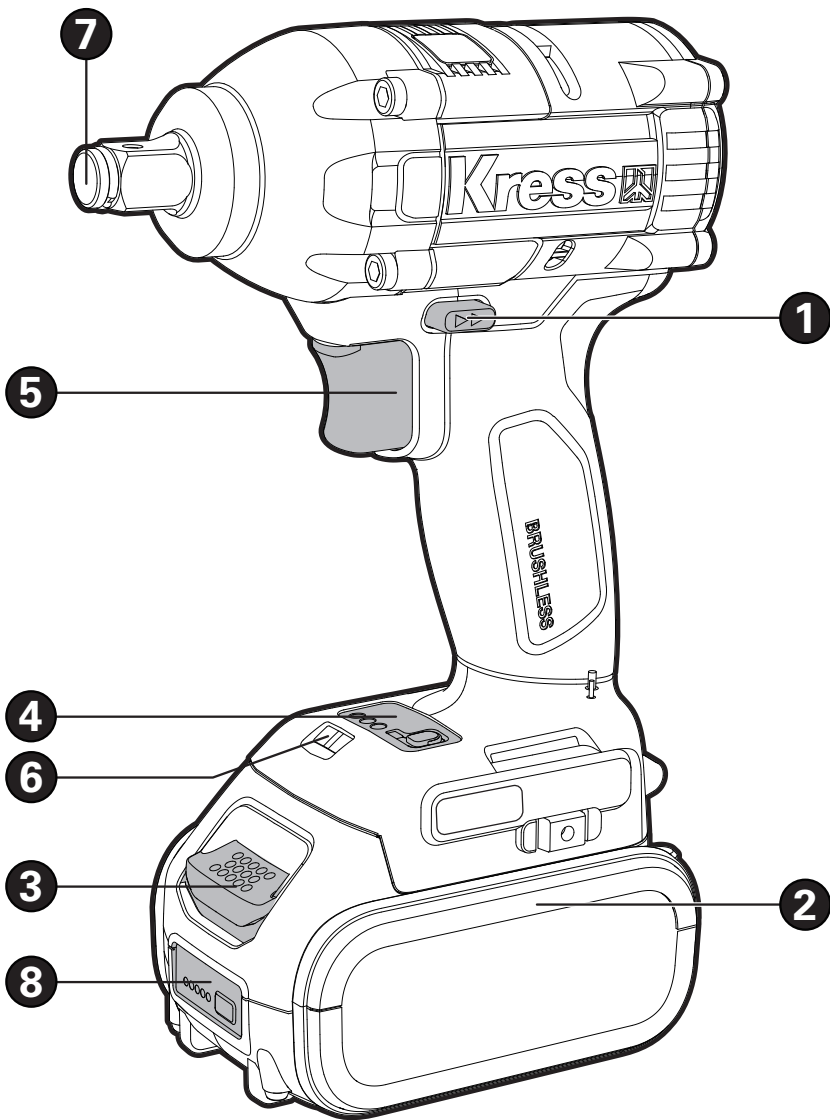

**Lithium-Ion Brushless Impact Wrench
KUB30 KUB30.2 KUB30.9**

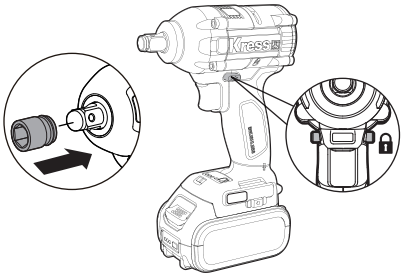
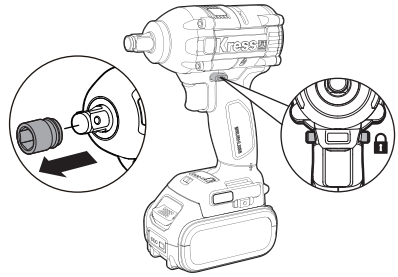
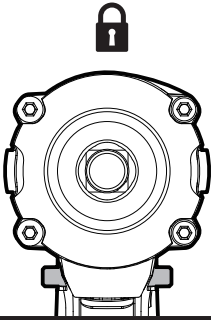
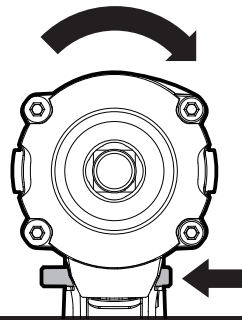
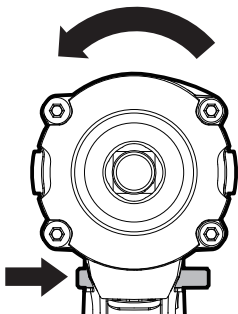
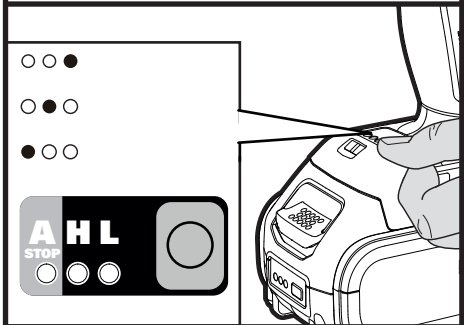
A1**A2****B****C1****C2****D**

Lithium-Ion Brushless Impact Wrench KUB30 KUB30.2 KUB30.9

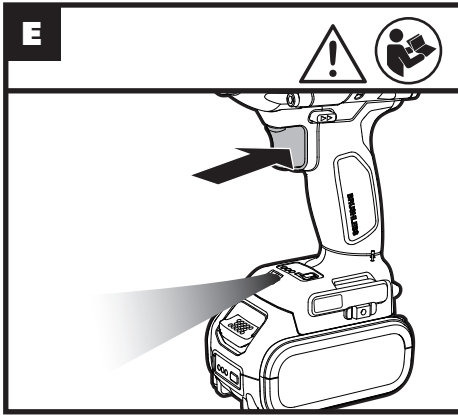

COMPONENT LIST

1. STEERING LEVER

2. BATTERY PACK *

3. BATTERY PACK LOCK KNOB *

4. SPEED ADJUSTMENT BUTTON

5. SWITCH

6. LED LIGHT

7. OUTPUT SHAFT

8. BATTERY INDICATOR

* Not all the accessories illustrated or described are included in standard delivery.

TECHNICAL DATA

Type designation: **KUB30 KUB30.2 KUB30.9**
(B30-designation of machinery, representative of impact wrench)

	KUB30 KUB30.2	KUB30.9
Voltage	20V  Max**	
No-load speed	0-1900/2200/min	
Impact rate	0-3000/3200bpm	
Max torque	300N.m	
Chuck size	12.7mm	
Machine weight	1.7kg	1.1kg
Battery capacity	4.0Ah	/

** Voltage measured without workload. Initial battery voltage reaches maximum of 20 volts. Nominal voltage is 18 volts.

ACCESSORIES

	KUB30	KUB30.2	KUB30.9
Battery pack (KAB21)	2	2	/
Charger (KAC21)	1	1	/
M22 socket	1	1	1
Belt	1	1	1
Parallel pin	1	1	1
O-shaped ring	1	1	1

We recommend that you purchase your accessories listed in the above list from the same store that sold you the tool. Refer to the accessory packaging for further details. Store personnel can assist you and offer advice.

OPERATION GUIDELINES





NOTE: Before using the tool, read the instruction book carefully.

Intended use:

This tool is intended for the fastening and loosening of bolts, nuts and various threaded fasteners. This tool is not intended for use as a drill.

ASSEMBLY AND OPERATION

Action	Figure
ASSEMBLY	
Installation and disassembly of socket	See Fig. A1, A2
OPERATION	
Steering lever  WARNING: The steering cannot be changed until the machine is completely static.	See Fig. B, C1, C2
VARIABLE SPEED ADJUSTMENT	See Fig. D
Operating the On/Off Switch  WARNING: Do not operate for long periods at low speed because excess heat will be produced internally.	See Fig. E

Using The Sight Light

Before operation, the LED light will be activated when the On/Off switch is slightly depressed, and will automatically turn off 20 seconds after the On/Off switch is released.

The Battery of impact wrench is equipped with a protection system. When the LED flashes for 3 seconds and then goes out, the system will automatically cut off the power to extend battery life. If the machine and battery pack are placed in the following locations, the machine may automatically power off during operation:

- **Overload:** If the tool is overloaded, the abnormally high current may be released; in this case, release the switch on the tool to stop the overloading operation; and then restart.
- **Overheat:** When the above situations occur, if the tool fails to start by pressing the switch, the tool and battery will overheat. In this case, cool the tool and battery pack before starting the switch again.
- **Low voltage:** The tool does not work when the remaining capacity is too low. In this case, remove and replace the battery pack.

See Fig. E

 **WARNING:** Press the switch to ensure that the steering lever is on both the left and right sides before turning the LED on.

TROUBLE SHOOTING

1. I CAN NOT FIT THE BATTERY INTO THE BATTERY CHARGER. WHY?

The battery can be inserted into the charger only in one direction. Turn the battery around until it can be inserted into the slot, the red LED Light should turn on when the battery is charging.

2. REASONS FOR DIFFERENT BATTERY PACK WORKING TIMES

Charging time problems, as above, and having not used a Battery Pack for a prolonged time will reduce the Battery Pack working time. This is the problem related with the number of charging. Such situation will be improved after charging and using for several times. Heavy working conditions such as large screws into hard wood will use up the Battery Pack energy faster than lighter working conditions. Do not re-charge your Battery Pack below 0°C and above 30°C as this will affect performance.



Kress 